

Direct Air Capture Technologies

Developments in capturing Carbon Dioxide from the atmosphere/biosphere using carbon capture and storage technologies - a lay person's view

Rob Meecham

Convenor Policy Team Sustainable Energy Now

The views expressed in this presentation are the Presenter's. The use of DAC is still under consideration by SEN.

Direct Air Capture (DAC) Technologies

Presentation will cover:

- ▶ The challenge
- ▶ The place of DAC technologies
- ▶ Current DAC technologies
- ▶ DAC potential in Western Australia
- ▶ Who will pay - need for government policies
- ▶ Private sector opportunities
- ▶ Concluding remarks

Key Take Aways

- ▶ DAC is a key technology to enable the world to deal with carbon dioxide in the atmosphere
- ▶ It is in the early stages of development and considerably more research and development is required for it to reach its full potential
- ▶ We need to start applying the technology we have now.

The Challenge

- ▶ Current concentration of CO₂ is approximately 413 ppm
- ▶ At the end of the pre-industrial period (18th Century) the concentration of CO₂ was 280 ppm
- ▶ This was the concentration of CO₂ at the top of the warming cycles for the previous 800,000 years
- ▶ Perhaps 280 ppm is an appropriate target for carbon extraction (we don't want to go too far, as unlikely as that seems)?
- ▶ Using 7.8 Gt CO₂ per 1 ppm implies 2,184 Gt in the atmosphere in 1800 and now around 3,221 Gt CO₂
- ▶ Implies 1,000 Gt of CO₂ needing to be removed to return to pre-industrial levels at the moment - at USD100/t that's US\$100 trillion world GDP \$75 trillion)
- ▶ But CO₂ will re-enter the atmosphere from oceans as concentrations reduce. Some estimates put the amount needing to be removed as high as 10,000 Gt CO₂
- ▶ Under current scenarios net zero means anywhere from 10 to 20 GT of CO₂ is still being emitted

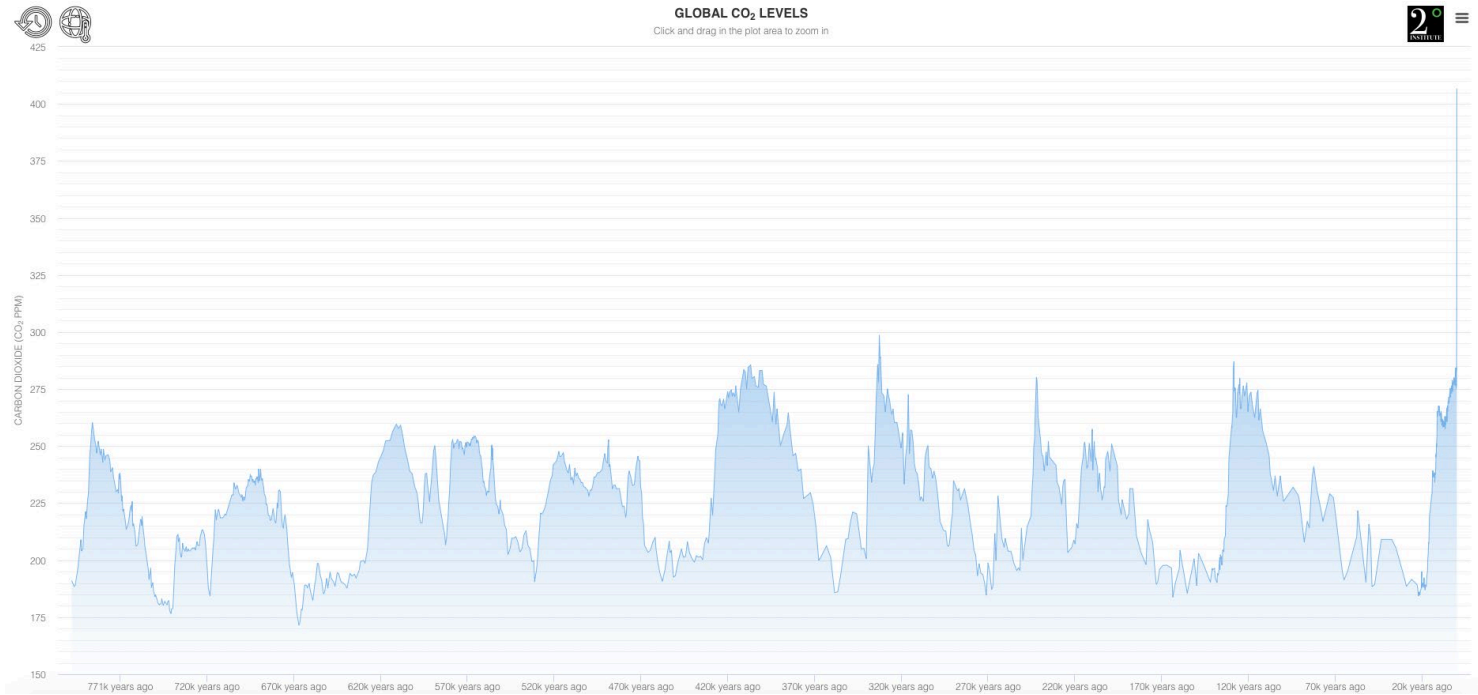

Global CO₂ levels for past 800,000 years

Carbon Dioxide to be removed



Carbon budget to keep under 2C is about 500 Gt given current UN figures



Add to current CO₂ concentration of 3221 Gt gives 3721 Gt CO₂ at around 470 ppm



Total CO₂ to be removed is a minimum of 1500 Gt (not considering natural transfers)

The tools we have for Carbon Dioxide removal

Reafforestation

Rangeland improvements

Soil improvement

Seaweed and other ocean farming

Enhanced mineralisation

DAC technologies

Current DAC technologies



Carbon Engineering - hydroxide process



Global Thermostat - amine catalyst



Climeworks - amine catalyst



CSIRO - liquid that absorbs CO₂



Small personalised devices

Carbon Engineering

- ▶ Liquid capture technology
- ▶ Uses natural gas to supply heat - needs $>800^{\circ}\text{C}$
- ▶ 300 - 500 MW needed to power a million ton per annum plant
- ▶ Water use issues (4.7 tons of water per ton CO_2)
- ▶ Captures the CO_2 emissions from the burning of the gas
- ▶ Uses the CO_2 for industrial purposes, including for enhanced oil recovery
- ▶ Challenge of finding someone to take the CO_2
- ▶ Currently building a 500,000 tpa plant in the Permian Basin (west Texas or SE New Mexico) - partnering with Occidental
- ▶ Intends to build 1 million tons per annum plants - relies on Californian subsidies (Low Carbon Fuel Standards) and federal government tax concessions
- ▶ BHP is a shareholder

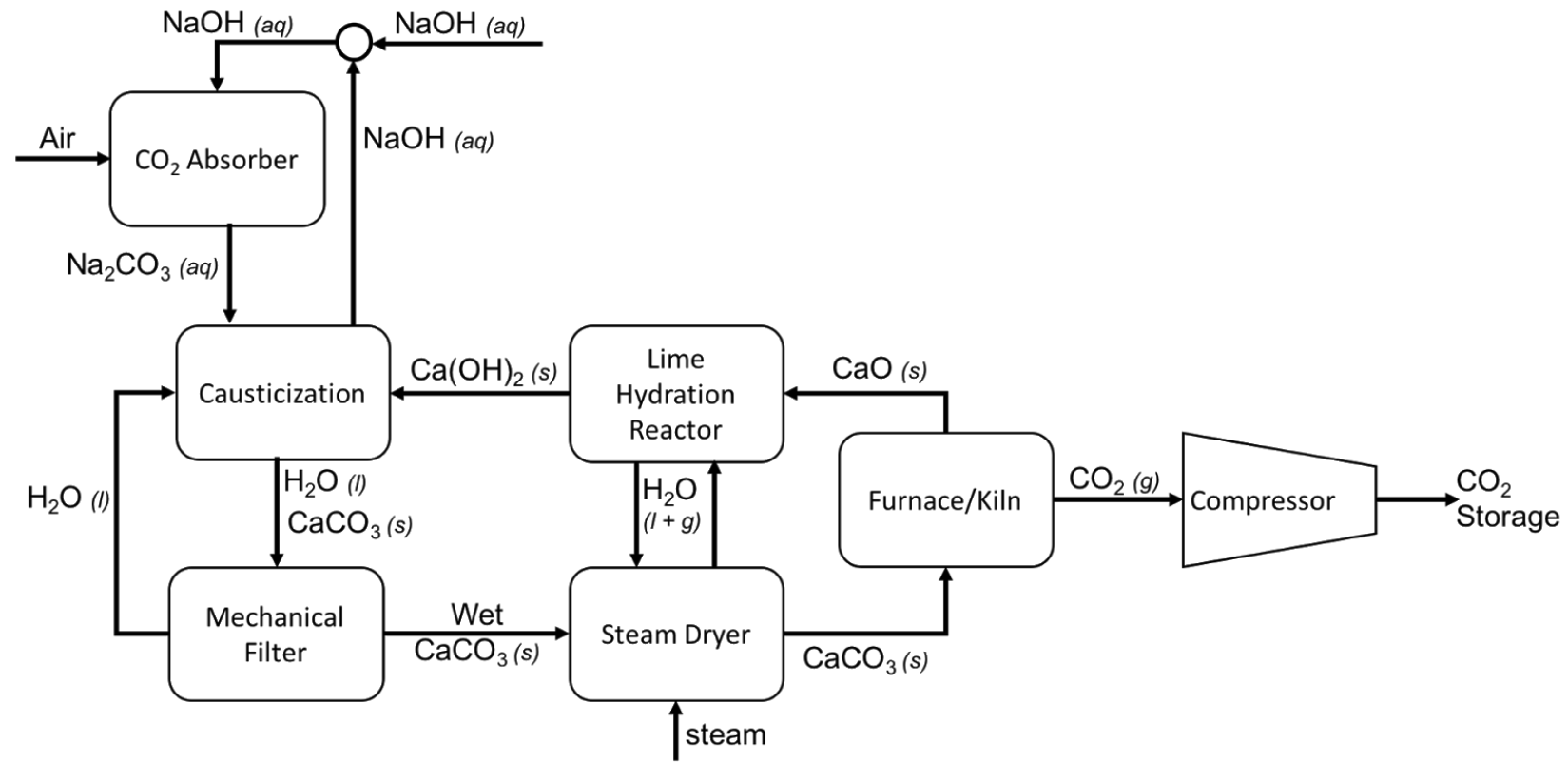

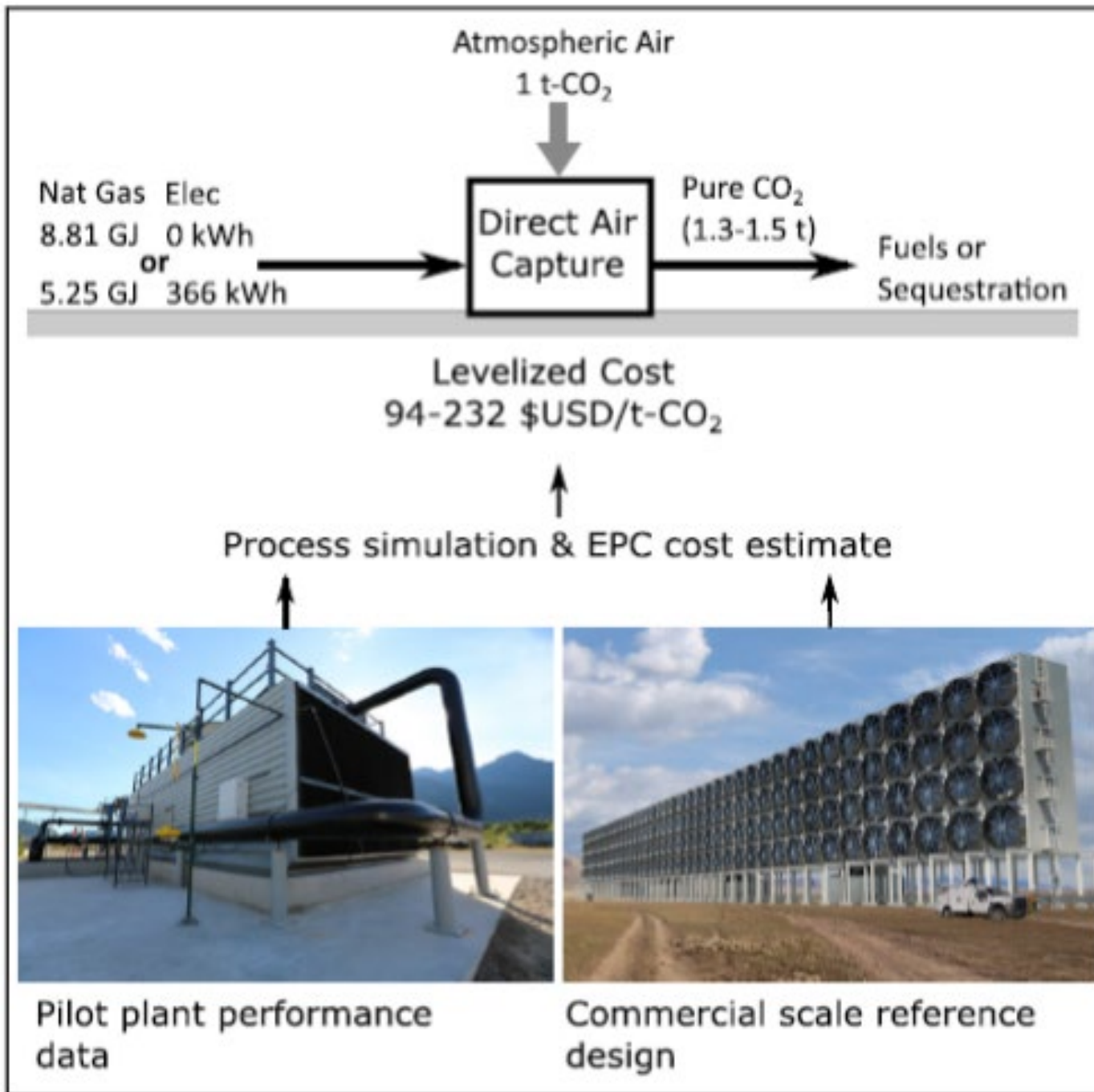

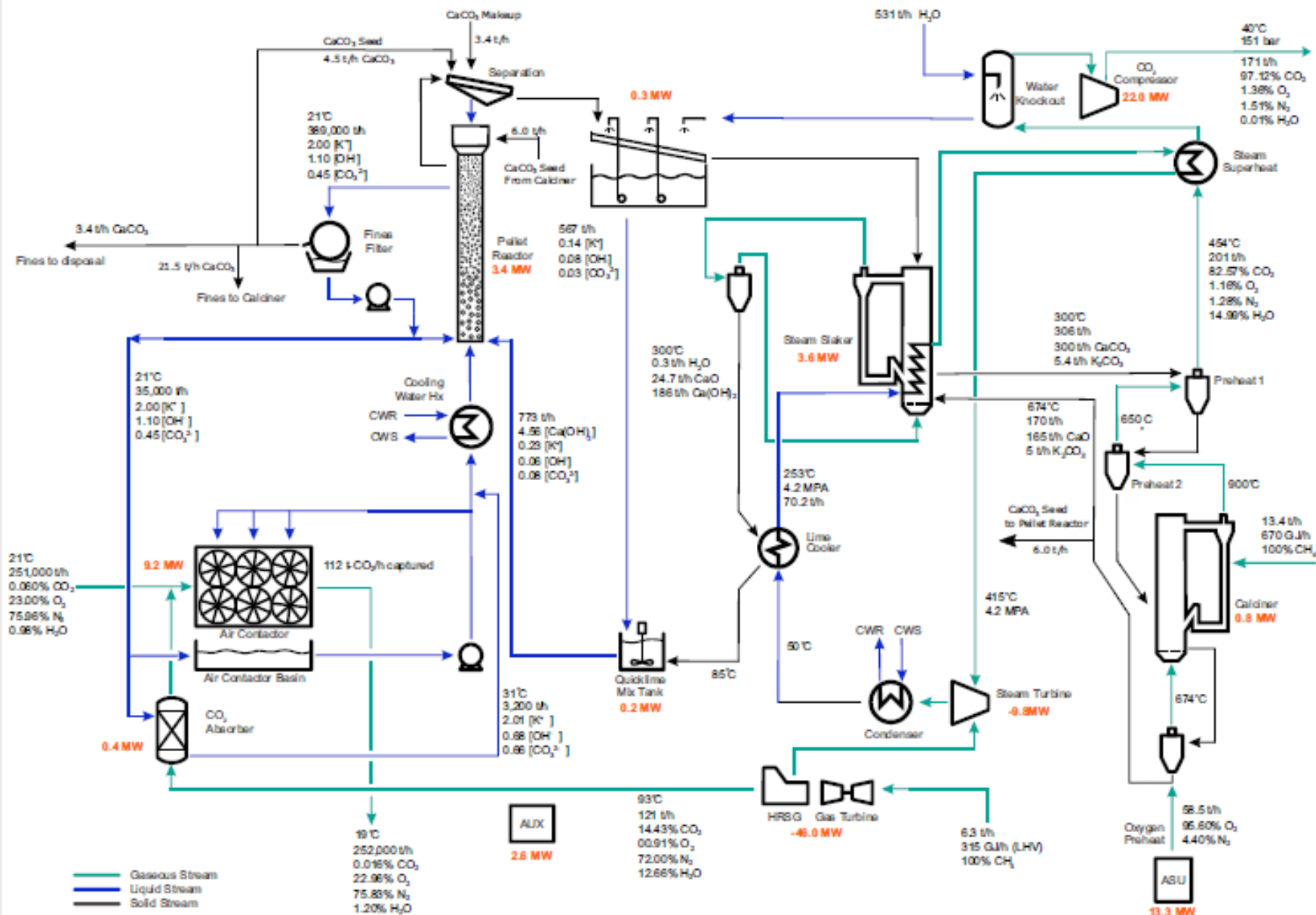

concentrations in mol/L
fractions in % by mass
t denotes metric tons

Global Thermostat

- ▶ Solid capture material
- ▶ Focus on heat efficiency
- ▶ 50,000 ton per annum plant costs of the order of AU\$40m and takes up about an acre of land
- ▶ ExxonMobil is now a partner

Climeworks

- ▶ Based on amine chemistry
- ▶ Two-step process
- ▶ Air is drawn into the collector with a fan
- ▶ Carbon dioxide is captured on the surface of a highly selective filter material that sits inside the collectors
- ▶ After the filter material is full with carbon dioxide, the collector is closed
- ▶ The temperature is increased to between 80 and 100 °C - this releases the carbon dioxide. The high-purity, high-concentration carbon dioxide is collected.

Climeworks

- ▶ Solid absorber
- ▶ Modular construction
- ▶ Uses geothermal heat, renewables or energy-from-waste to supply the energy needed
- ▶ Apparently still of the order of US\$600 per ton to capture CO₂ (2018)
- ▶ Claims to recover 90% of CO₂ from the airstream - “Grey emissions are below 10%, which means that out of 100 tons of carbon dioxide that our machines capture from the air, at least 90 tons are permanently removed and only up to 10 tons are re-emitted.”
- ▶ Working with Iceland to develop technologies that mineralise the CO₂ captured

**Geothermal
Power Plant**

Climeworks

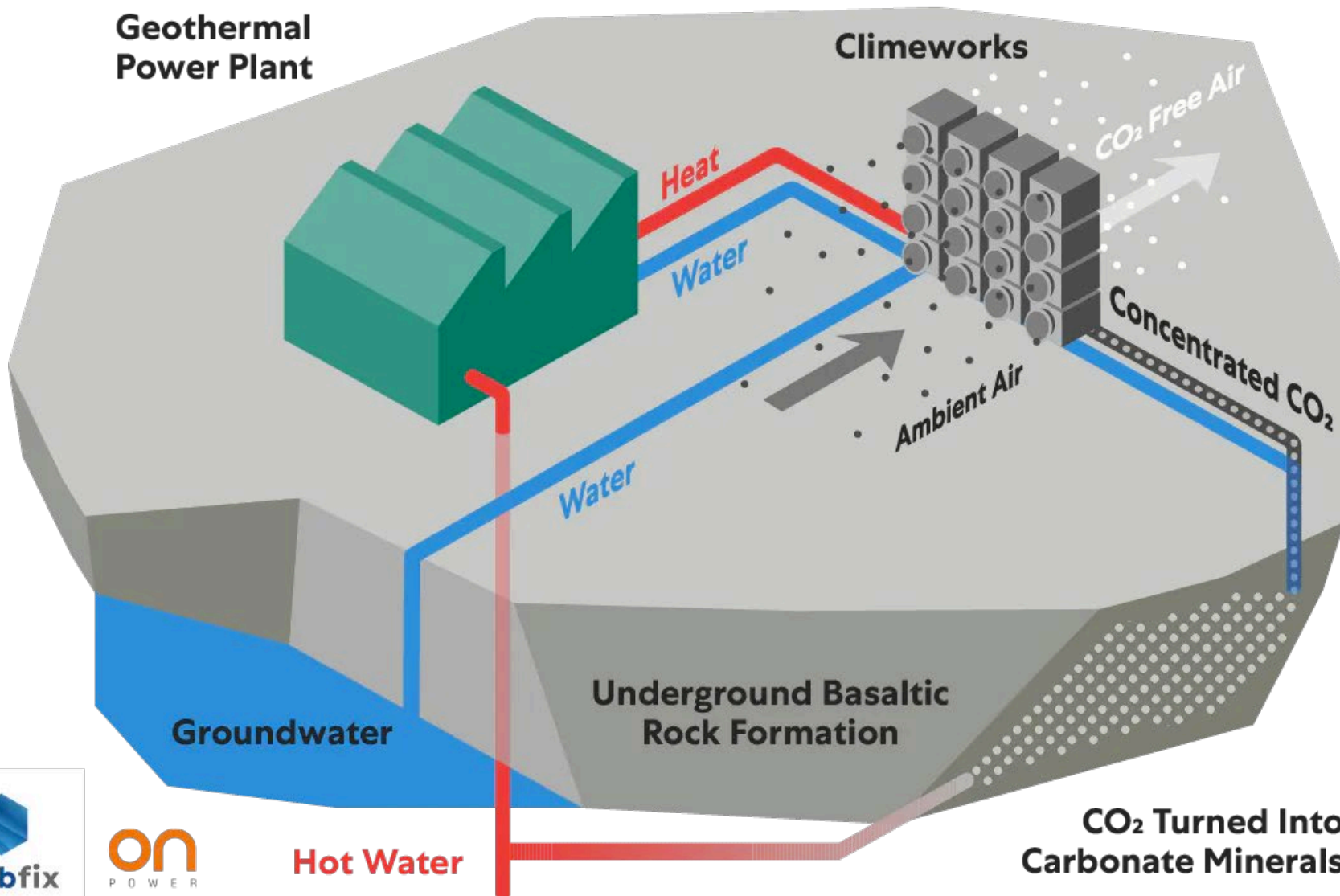

CLOSING THE CARBON CYCLE

Renewable fuels created from CO₂ and Water

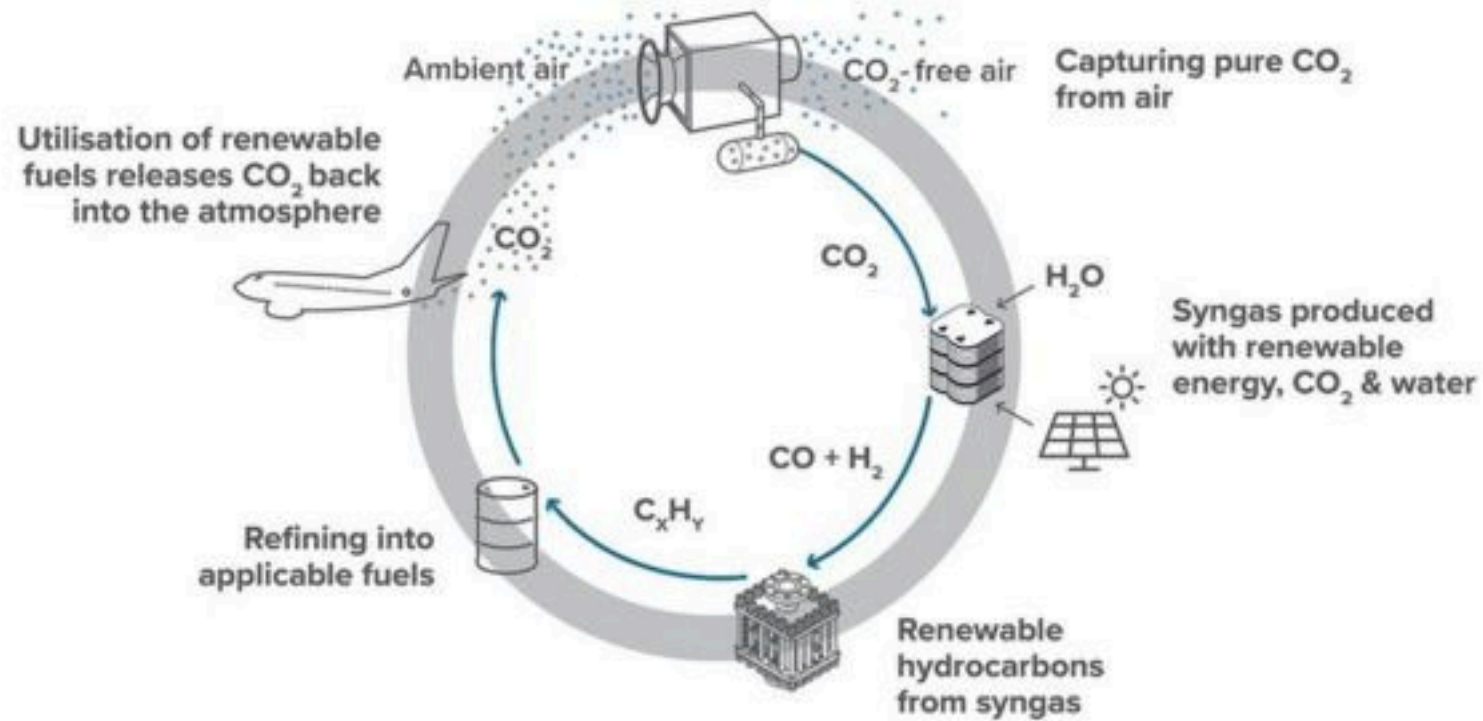

CSIRO

- ▶ The Ambient CO₂ Harvester





MIT Research - a battery that collects CO₂

- ▶ Electrochemical cell traps carbon dioxide from gas flowing across the surface of its thin, flexible electrodes
- ▶ The negative electrode is coated with a composite of polyanthraquinone and carbon nanotubes, while the positive electrode is coated with a polyvinylferrocene-carbon nanotube mix
- ▶ When the battery is charging, electrons travel from the ferrocene to the quinone side through the external circuit
- ▶ In that reduced state, the quinone reacts with carbon dioxide, forming a carbonate salt and incorporating the gas into the solid electrode
- ▶ Discharging the cell reverses the reaction, regenerating the quinone and releasing carbon dioxide, which can be flushed out using another stream of carrier gas

General points

- ▶ 4 Gt of CO₂ locked up in the Amazon Rain Forest - sequesters 1.2 Gt per annum
- ▶ DAC technologies can extract the same amount in a facility the size of New Jersey (150 KM² - 22,500 sq km), including the area needed for the renewable energy generation (about 1/500th the size of the Amazon)
- ▶ Storage available: Royal Society of Engineers: 900 Gt of available reservoirs already identified
- ▶ DAC may use up to a quarter of world energy production in 2100 (Nature Communications)

Potential in Western Australia

- ▶ Renewable energy resource
- ▶ Land availability
- ▶ Some infrastructure in place - Collie will have significant transmission infrastructure available to convert to DAC use
- ▶ Significant storage potential nearby in the Lesueur Formation
- ▶ Opportunity to “export” - that is undertake extraction for countries unable to extract their own emissions
- ▶ Carnarvon Basin has significant capacity to absorb CO₂ in reservoirs from which oil and gas has been extracted

Who will pay to remove CO₂ from the atmosphere? The need for government action

- ▶ Ultimately a significant proportion of the removal of CO₂ from the atmosphere will need to be funded by the community
- ▶ Business at most will remove their own emissions(eg Microsoft)
- ▶ The emissions of businesses that won't remove their emissions or the emissions that occur when their products are used, or no longer exist, must still be removed
- ▶ Government policy will have to address this issue
- ▶ Governments are unlikely to move until a substantial majority of the community understand and support governments taking action on the issue
- ▶ Its like sewerage - no one thought of paying to deal with sewerage in 19 century - now its an accepted part of the economy
- ▶ Equitable shares of CDR responsibility
- ▶ US Senate: CREATE Act - a bill that would ensure the US has a strategic plan to quickly and robustly scale up carbon removal solutions across sectors (mid July 2020 - Carbon 180). Also budget allocates funding for CCS research and development.

Private Sector Opportunity

- ▶ Companies committing to net zero by 2050
- ▶ Will need to offset emissions in most cases
- ▶ If committing to also remove past carbon emissions will need to extract carbon dioxide from the atmosphere
- ▶ A key issue is obtaining offtake agreements
- ▶ Businesses can acknowledge their responsibilities and start purchasing capture and storage at least for part of their emissions to get the industry underway
- ▶ Eventually price of carbon will increase and cost of extraction will reduce until it is economically viable to extract and store or utilise the carbon dioxide captured

Future Developments

- ▶ Heliogen developed a system that concentrates solar power to very high heat levels. Both could reduce the energy input needed for current direct air capture systems -- one of the technology's main drawbacks.
- ▶ Another way to get energy: Heat and electricity that are not currently being used. Direct air capture has the flexibility to be sited most anywhere, so could be built near locations where renewable energy isn't being fed into the grid, for example.
- ▶ Research is also under way to map sources of waste heat---including thermal energy from flared natural gas, or geothermal or nuclear power plants---that could also power direct air capture plants. These sources aren't big enough to power *all* the direct air capture we might need but could power it in the near term.

DAC must not prolong fossil fuel use

- ▶ The cheapest method of removing CO₂ is not to put it there in the first place
- ▶ 30 million small scale or 30,000 large systems (cf 10,000 coal fired power stations)
- ▶ Minimisation of emissions is essential if the rate of increase in temperature is to be abated
- ▶ Efforts must continue to stop emissions - DAC is a backstop not a panacea
- ▶ Non-fossil carbon sources of energy must be adopted as rapidly as possible
- ▶ DAC's main purpose must be to reduce the concentration of carbon dioxide in the atmosphere
- ▶ DAC should not be used to offset future CO₂ emissions in an attempt to slow the transition to renewable energy
- ▶ The volume of carbon dioxide needing to be removed from the atmosphere is substantial and DAC will not be able to perform both offsetting and carbon concentration reduction roles simultaneously

Conclusion

- ▶ Funds starting to flow into research
- ▶ Consensus developing that we have to use DAC to meet the climate challenge
- ▶ We have to use all the tools at our disposal not just DAC
- ▶ Need to bring the community into the debate - need “an interdisciplinary, holistic approach to carbon dioxide removal”
- ▶ DAC is not a panacea that will allow us to keep emitting carbon dioxide - we have to eliminate emissions as soon as we can and extract the residual as fast as we can.

Key Take Aways

- ▶ DAC is a key technology to enable the world to deal with carbon dioxide in the atmosphere
- ▶ It is in the early stages of development and considerably more research and development is required for it to reach its full potential
- ▶ We need to start applying the technology we have now.

Acknowledgements

- ▶ Jennifer Wilcox
https://www.ted.com/talks/jennifer_wilcox_a_new_way_to_remove_co2_from_the_atmosphere?language=en
- ▶ David W. Keith, Geoffrey Holmes, David St. Angelo, Kenton Heidel: **A Process for Capturing CO₂ from the Atmosphere.**
<https://doi.org/10.1016/j.joule.2018.05.006>
- ▶ Royal Society and Royal Society of Engineers: Greenhouse Gas Removal
royalsociety.org/greenhouse-gas-removal
raeng.org.uk/greenhousegasremoval
- ▶ National Academy of Sciences: Negative Emissions Technologies and Reliable Sequestration: A Research Agenda <http://nap.edu/25259>
- ▶ [TEMPERATURERECORD.ORG](https://www.temperaturerecord.org)
- ▶ [Carbonplan.org](https://www.carbonplan.org)
- ▶ [Carbon180.org](https://www.carbon180.org)

Acknowledgements

- ▶ An inter-model assessment of the role of direct air capture in deep mitigation pathways. Giulia Realmonte et al Nature Communications 10 Article Number 3277 (2019) Published 22 July 2020 via web
- ▶ Carbonbrief.org Who should be responsible for removing CO₂ from the atmosphere? <https://www.carbonbrief.org/guest-post-who-should-be-responsible-for-removing-co2-from-the-atmosphere>
- ▶ <https://cen.acs.org/environment/climate-change/Battery-like-device-remove-carbon/97/i43>
- ▶ <https://carbonengineering.com/>
- ▶ <https://globalthermostat.com/>
- ▶ <https://www.climeworks.com/>
- ▶ <https://www.csiro.au/en/Research/EF/Areas/Renewable-and-low-emission-tech/Carbon-capture-storage/Ambient>
- ▶ <https://vimeo.com/423393751>